

AF Series – Bare Tube Bundle Shell & Tube Water to Oil Cooling

The A/SA Series is very versatile in its ability to accommodate multiple application requirements. 600 and 800 sizes offer 1/4" tube and 1000, 1200, and 1600 sizes feature 3/8" tube.

A series is a non-ferrous, Brass construction, which makes it ideal for water to water, including sea water cooling applications.

The SA series is a competitively priced steel construction version of the A series, and mainly used for standard hydraulic applications. Steel/cast iron components offer a lower cost solution. SA is only available in 1200 and 1600 sizes.



Options

Non-ferrous construction (water-to-water service)

90/10 copper nickel cooling tubes, bronze end bonnets for sea water service and zinc anodes

How to Order

Model Series

AF - SAE 4 Bolt Flange (with UNC threads) Shell side connections; NPT Tube side connections

Model Size Selected

608, 614, 624, 814, 824, 836, 1014, 1024, 1036, 1224, 1236, 1248, 1260, 1624, 1636, 1648, 1660, 1672
(See Performance Curve Chart on page 3 for sizes)

Baffle Spacing

1, 1.5, 2, 3, 4, 6
(See Performance Curve Chart on page 3 for options)

Tube Diameter Code

4 - 1/4" (600 & 800 Sizes only)
6 - 3/8" (1000, 1200 & 1600 Sizes only)

Tubeside

O - One Pass
T - Two Pass
F - Four Pass

Shell Material

Blank - Steel (SA Series Only)
BR - Brass

Cooling Tube Material

Blank - Copper
CN - Copper Nickel

End Bonnet Material

Blank - Cast Iron
B - Bronze (A Series Only)

Zinc Anodes

Blank - None
Z - Zinc

Features

ITT Interchange

B or HC Series is Recommended for New Applications

Sea Water Applications (A Series Only), End Model Code with BR-CN-B-Z

Water to Water Applications (A Series Only)

Cooling Tube Side Material Options

- Standard Steel
- Copper Nickel
- Bronze

Multiple Connection Options (shell x tube)

- NPT x NPT
- SAE x NPT
- Sae Code 61 x NPT
- BSPP x BSP

End Bonnets Removable for Servicing

Mounting Feet Included (May be Rotated in 90° Increments)

Ratings

Maximum Operating Pressure

- Shell Side 300 PSI

Maximum Operating Pressure

- Tube Side 150 PSI

Maximum Operating Temperature 300°F

Heat Rejection from 2-350 HP

Oil Flow from 3-200 GPM

Materials

Shell Steel/Brass

Tubes Copper/Copper Nickel

Hubs & Tubesheets Steel/Brass

Baffles Brass

End Bonnets Cast Iron/Bronze

Mounting Brackets Steel

Gaskets Nitrile Rubber/Cellulose Fiber

Nameplate Aluminum Foil

Piping Diagram

One Pass

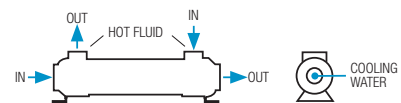

Two and Four Pass



Specific applications may have different piping arrangements. Contact factory for assistance.

Selection Procedure

Performance Curves are based on 100SSU oil leaving the cooler 40°F higher than the water temperature used for cooling. This is also referred to as a 40°F approach temperature. Curves are based on a 2:1 oil to water flow ratio.

STEP 1 Determine the Heat Load. This will vary with different systems, but typically coolers are sized to remove 25 to 50% of the input nameplate horsepower. (Example: 100 HP Power Unit x .33 = 33 HP Heat load.)

$$\text{If BTU/HR is known: } \text{HP} = \frac{\text{BTU/HR}}{2545}$$

STEP 1 Determine Approach Temperature. Desired oil leaving cooler °F – Water Inlet temp. °F = Actual Approach (Max. reservoir temp.)

STEP 1 Determine Curve Horsepower Heat Load. Enter the information from above:

$$\text{Horsepower heat load} \times \frac{40}{\text{Actual Approach}} \times \text{Viscosity Correction A} = \text{Curve Horsepower}$$

STEP 1 Enter curves at oil flow through cooler and curve horsepower. Any curve above the intersecting point will work.

STEP 1 Determine Oil Pressure Drop from Curves:
 ● = 5 PSI ■ = 10 PSI ▲ = 20 PSI Multiply pressure drop from curve by correction factor B found on oil viscosity correction curve.

Oil Temperature

Oil coolers can be selected using entering or leaving oil temperatures.

Typical operating temperature ranges are:

Hydraulic Oil	110°F - 130°F
Hydrostatic Drive Oil	130°F - 180°F
Bearing Lube Oil	120°F - 160°F
Lube Oil Circuits	110°F - 130°F

Desired Reservoir Temperature

Return Line Cooling: Desired temperature is the oil temperature leaving the cooler. This will be the same temperature that will be found in the reservoir.

Off-Line Recirculation Cooling Loop: Desired temperature is the oil temperature entering the cooler. In this case, the oil temperature change must be determined so that the actual oil leaving temperature can be found. Calculate the oil temperature change (oil ΔT) with this formula:

$$\text{Oil } \Delta T = (\text{BTUs/HR}) / (\text{GPM Oil Flow} \times 210).$$

To calculate the oil leaving temperature from the cooler, use this formula:

$$\text{Oil Leaving Temp.} = \text{Oil Entering Temp.} - \text{Oil } \Delta T.$$

This formula may also be used in any application where the only temperature available is the entering oil temperature.

Oil Pressure Drop: Most systems can tolerate a pressure drop through the heat exchanger of 20 to 30 PSI. Excessive pressure drop should be avoided. Care should be taken to limit pressure drop to 5 PSI or less for case drain applications where high back pressure may damage the pump shaft seals.

Viscosity Correction

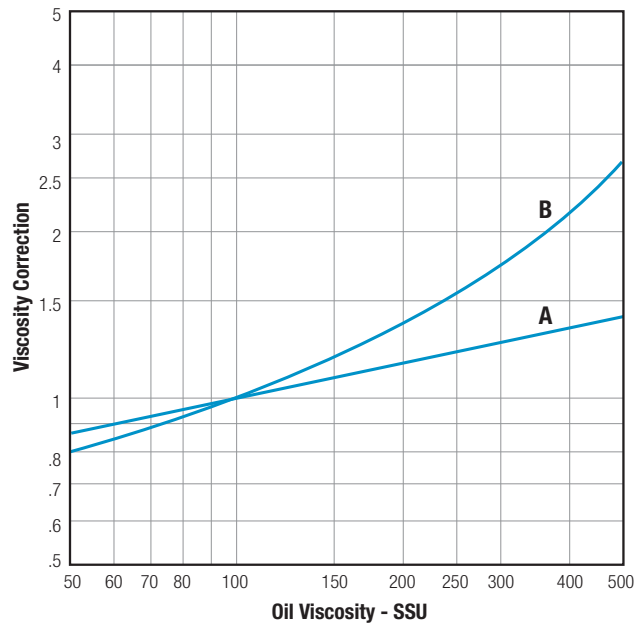

Maximum Flow Rates

Example Model No.

A - 1024 - 2 - 6 - F

Unit Size	Baffle Spacing	Shell Side (GPM)	Tube Side (GPM)		
			O	T	F
608	1, 2	14, 29	48	24	12
614	1.5, 4	21, 29	48	24	12
624	2, 4	29	48	24	12
814	1.5, 3	29, 57	87	44	22
824 & 836	2, 4	38, 69	87	44	22
1014	1.5, 3	32, 64	146	73	37
1024 & 1036	2, 4	42, 69	146	73	37
1224	2, 4	51, 103	224	112	56
1236 & 1248	3, 6	77, 115	224	112	56
1260	4, 6	103, 115	224	112	56
1624	2, 6	66, 200	280	140	70
1636 & 1648	3, 6	100, 200	280	140	70
1660 & 1672	4, 6	133, 200	280	140	70

Caution: Incorrect installation can cause this product to fail prematurely, causing the shell side and tube side fluids to intermix.

Performance Curves

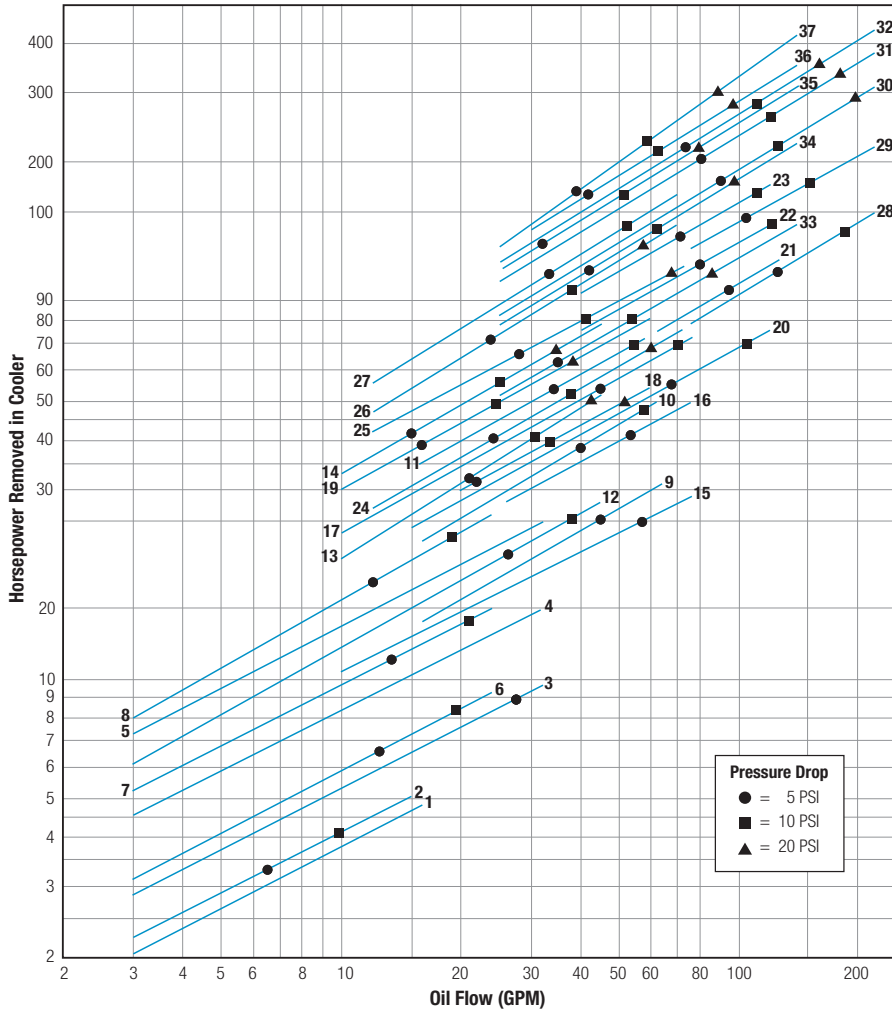

Curve Number	Model	Shipping Weight (LBS)
3	A-608-2-4-F	12
4	A-614-4-4-F	17
5	A-624-4-4-F	20
6	A-608-1-4-F	12
7	A-614-1.5-4-F	17
8	A-624-2-4-F	20
9	A-814-3-4-F	40
10	A-824-4-4-F	50
11	A-836-4-4-F	58
12	A-814-1.5-4-F	40
13	A-824-2-4-F	50
14	A-836-2-4-F	58
15	A-1014-3-6-F	49
16	A-1024-4-6-F	63
17	A-1036-4-6-F	72
18	A-1024-2-6-F	63
19	A-1036-2-6-F	72
20	A-1224-4-6-F	78
21	A-1236-6-6-F	118
22	A-1248-6-6-F	143
23	A-1260-6-6-F	165
24	A-1224-2-6-F	78
25	A-1236-3-6-F	118
26	A-1248-3-6-F	143
27	A-1260-4-6-F	165
28	A-1624-6-6-F	180
29	A-1636-6-6-F	210
30	A-1648-6-6-F	250
31	A-1660-6-6-F	286
32	A-1672-6-6-F	330
33	A-1624-2-6-F	180
34	A-1636-3-6-F	210
35	A-1648-3-6-F	250
36	A-1660-4-6-F	286
37	A-1672-4-6-F	330

Shipping weights are approximate.

Dimensions

One Pass

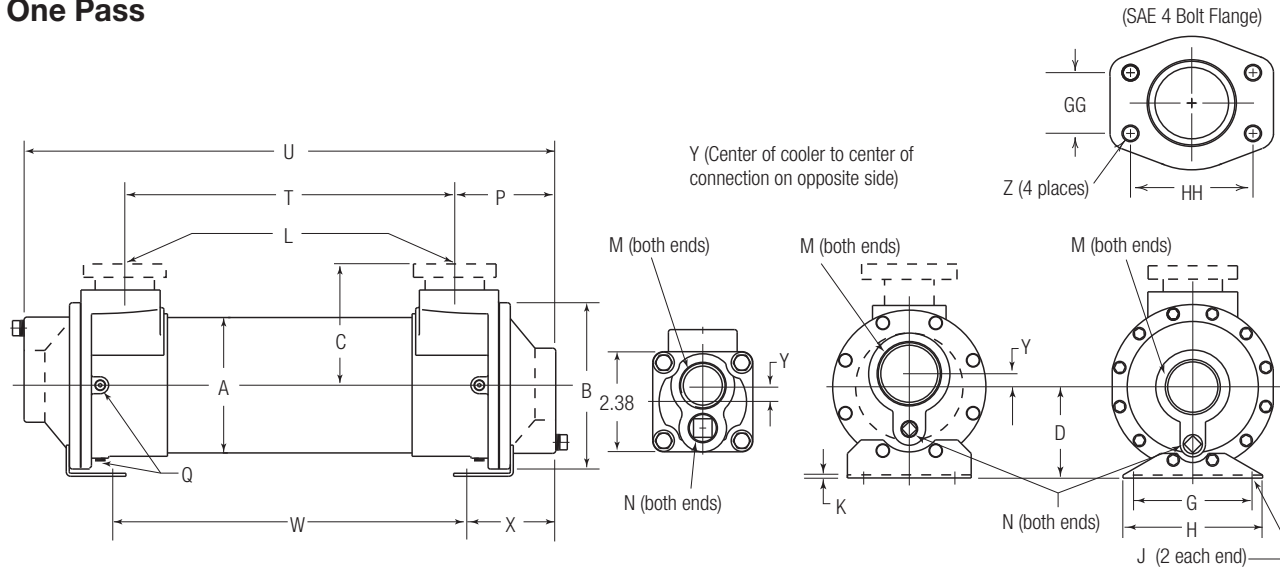

**A-600
A-800 Series**

**A-1000, A-1200
A-1600 Series**

Flange Size	GG	HH	Z - CF	Z - CFM
1	1.03	2.06	3/8-16 UNC	M-10
1.50	1.41	2.75	1/2-13 UNC	M-12
2	1.69	3.06	1/2-13 UNC	M-12
3	2.44	4.19	5/8-11 UNC	M-16

Model	A Dia.	B Dia.	C		D	G	H	J	K	L		M NPT	N NPT	P	Q NPT	T	U	W	X	Y	
			NPT/BSPP SAE O-Ring	SAE 4 Bolt Flange						NPT/BSPP Flange	SAE O-Ring										
A-608	3.12	4.19	2.44	C/F	2.44	2.50	3.50	.38 x .88	.12	1.00	#16,	1.50	.38	2.56	(2) .25	6.12	11.25	5.47	3.06	.38	
A-614	3.12	4.19	2.44	C/F	2.44	2.50	3.50	.38 x .88	.12	1.00	1 1/4-12	1.50	.38	2.56	(2) .25	12.12	17.25	11.47	3.06	.38	
A-624	3.12	4.19	2.44	C/F	2.44	2.50	3.50	.38 x .88	.12	1.00	UNF-2B	1.50	.38	2.56	(2) .25	22.12	27.25	21.47	3.06	.38	
A-814	4.12	5.88	3.12	C/F	3.50	3.50	4.75	.50 x 1.62	.12	1.50	#24, 1 1/8-12 UN-2B	2.00	.38	3.44	(6) .38	11.12	18.00	12.88	2.56	.50	
A-824	4.12	5.88	3.12	C/F	3.50	3.50	4.75	.50 x 1.62	.12	1.50		2.00	.38	3.44	(6) .38	21.12	28.00	22.88	2.56	.50	
A-836	4.12	5.88	3.12	C/F	3.50	3.50	4.75	.50 x 1.62	.12	1.50		2.00	.38	3.44	(6) .38	33.12	40.00	34.88	2.56	.50	
A-1014	5.12	6.50	3.62	4.34	3.50	4.00	5.00	.44 x 2.20	.12	1.50		2.50	.38	3.69	(6) .25	11.12	18.50	11.75	3.38	.50	
A-1024	5.12	6.50	3.62	4.34	3.50	4.00	5.00	.44 x 2.20	.12	1.50		2.50	.38	3.69	(6) .25	21.12	28.50	21.75	3.38	.50	
A-1036	5.12	6.50	3.62	4.34	3.50	4.00	5.00	.44 x 2.20	.12	1.50		2.50	.38	3.69	(6) .25	33.12	40.50	33.75	3.38	.50	
A-1224	6.12	7.50	4.25	4.84"	4.12	5.00	6.00	.50 x .88	.12	2.00		#32, 2 1/2-12 UN-2B	3.00	.50	4.25	(6) .25	20.50	29.00	21.50	3.75	.50
A-1236	6.12	7.50	4.25	4.84"	4.12	5.00	6.00	.50 x .88	.12	2.00			3.00	.50	4.25	(6) .25	32.50	41.00	33.50	3.75	.50
A-1248	6.12	7.50	4.25	4.84"	4.12	5.00	6.00	.50 x .88	.12	2.00			3.00	.50	4.25	(6) .25	44.50	53.00	45.50	3.75	.50
A-1260	6.12	7.50	4.25	4.84"	4.12	5.00	6.00	.50 x .88	.12	2.00			3.00	.50	4.25	(6) .25	56.50	65.00	57.50	3.75	.50
A-1624	8.00	9.75	5.62	6.12"	5.38	7.00	8.25	.62 x 1.12	.19	3.00	—	3.00	.50	6.00	(6) .25	19.00	31.00	20.50	5.25	.50	
A-1636	8.00	9.75	5.62	6.12"	5.38	7.00	8.25	.62 x 1.12	.19	3.00	—	3.00	.50	6.00	(6) .25	31.00	43.00	44.50	5.25	.50	
A-1648	8.00	9.75	5.62	6.12"	5.38	7.00	8.25	.62 x 1.12	.19	3.00	—	3.00	.50	6.00	(6) .25	43.00	55.00	44.50	5.25	.50	
A-1660	8.00	9.75	5.62	6.12"	5.38	7.00	8.25	.62 x 1.12	.19	3.00	—	3.00	.50	6.00	(6) .25	55.00	67.00	56.50	5.25	.50	
A-1672	8.00	9.75	5.62	6.12"	5.38	7.00	8.25	.62 x 1.12	.19	3.00	—	3.00	.50	6.00	(6) .25	67.00	79.00	68.50	5.25	.50	

SAF-1200 5.88. *SAF-1600 7.38.

NOTE: We reserve the right to make reasonable design changes without notice. Consult factory. All dimensions are inches.

Dimensions

Two Pass

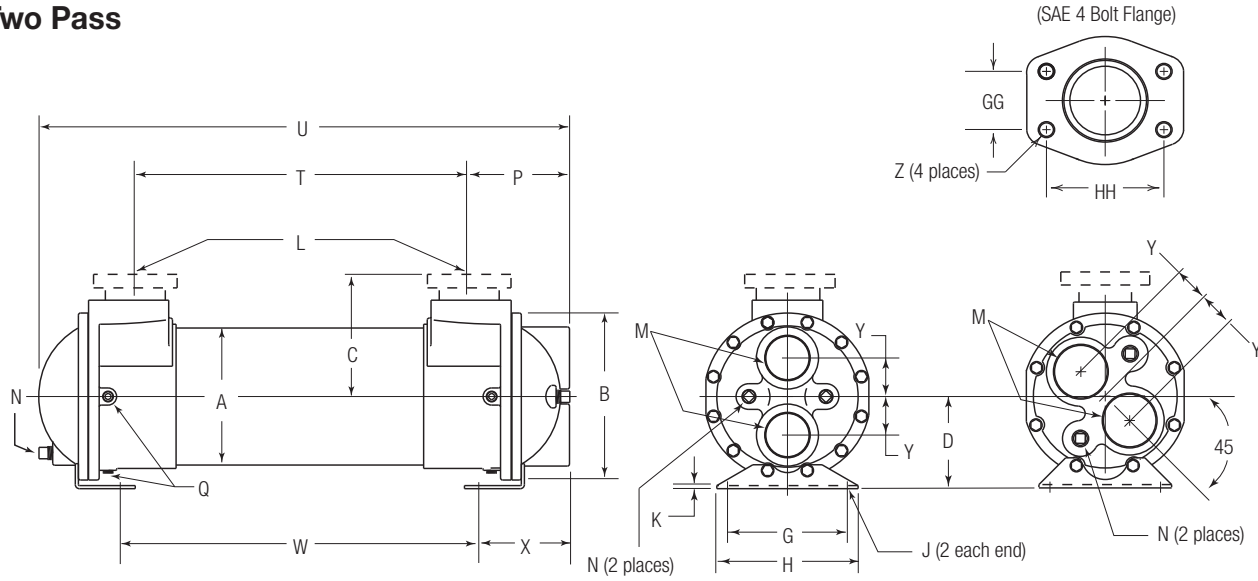

**A-600, A-800, A-1000
A-1600 Series**

A-1200 Series

Flange Size	GG	HH	Z - CF	Z - CFM
1	1.03	2.06	3/8-16 UNC	M-10
1.50	1.41	2.75	1/2-13 UNC	M-12
2	1.69	3.06	1/2-13 UNC	M-12
3	2.44	4.19	5/8-11 UNC	M-16

Model	A Dia.	B Dia.	C		D	G	H	J	K	L		M NPT	N NPT	P	Q NPT	T	U	W	X	Y
			NPT/BSPP SAE O-Ring	SAE 4 Bolt Flange						NPT/BSPP Flange	SAE O-Ring									
A-608	3.12	4.19	2.44	C/F	2.44	2.50	3.50	.38 x .88	.12	1.00	1.00	.38	2.44	(2) .25	6.12	10.75	5.47	2.94	1.00	
A-614	3.12	4.19	2.44	C/F	2.44	2.50	3.50	.38 x .88	.12	1.00	1.00	.38	2.44	(2) .25	12.12	16.75	11.47	2.94	1.00	
A-624	3.12	4.19	2.44	C/F	2.44	2.50	3.50	.38 x .88	.12	1.00	1.00	.38	2.44	(2) .25	22.12	26.75	21.47	2.94	1.00	
A-814	4.12	5.88	3.12	C/F	3.50	3.50	4.75	.50 x 1.62	.12	1.50	1.50	.38	3.44	(6) .38	11.12	17.62	12.88	2.56	1.19	
A-824	4.12	5.88	3.12	C/F	3.50	3.50	4.75	.50 x 1.62	.12	1.50	1.50	.38	3.44	(6) .38	21.12	27.62	22.88	2.56	1.19	
A-836	4.12	5.88	3.12	C/F	3.50	3.50	4.75	.50 x 1.62	.12	1.50	1.50	.38	3.44	(6) .38	33.12	39.62	34.88	2.56	1.19	
A-1014	5.12	6.50	3.62	4.34	3.50	4.00	5.00	.44 x 2.20	.12	1.50	1.50	.38	3.69	(6) .25	11.12	18.31	11.75	3.38	1.50	
A-1024	5.12	6.50	3.62	4.34	3.50	4.00	5.00	.44 x 2.20	.12	1.50	1.50	.38	3.69	(6) .25	21.12	28.31	21.75	3.38	1.50	
A-1036	5.12	6.50	3.62	4.34	3.50	4.00	5.00	.44 x 2.20	.12	1.50	1.50	.38	3.69	(6) .25	33.12	40.31	33.75	3.38	1.50	
A-1224	6.12	7.50	4.25	4.84	4.12	5.00	6.00	.50 x .88	.12	2.00	2.00	.50	4.25	(6) .25	20.50	28.75	21.50	3.75	1.56	
A-1236	6.12	7.50	4.25	4.84	4.12	5.00	6.00	.50 x .88	.12	2.00	2.00	.50	4.25	(6) .25	32.50	40.75	33.50	3.75	1.56	
A-1248	6.12	7.50	4.25	4.84	4.12	5.00	6.00	.50 x .88	.12	2.00	2.00	.50	4.25	(6) .25	44.50	52.75	45.50	3.75	1.56	
A-1260	6.12	7.50	4.25	4.84	4.12	5.00	6.00	.50 x .88	.12	2.00	2.00	.50	4.25	(6) .25	56.50	64.75	57.50	3.75	1.56	
A-1624	8.00	9.75	5.62	6.12	5.38	7.00	8.25	.62 x 1.12	.19	3.00	3.00	.50	6.00	(6) .25	19.00	30.50	20.50	5.25	2.25	
A-1636	8.00	9.75	5.62	6.12	5.38	7.00	8.25	.62 x 1.12	.19	3.00	3.00	.50	6.00	(6) .25	31.00	42.50	44.50	5.25	2.25	
A-1648	8.00	9.75	5.62	6.12	5.38	7.00	8.25	.62 x 1.12	.19	3.00	3.00	.50	6.00	(6) .25	43.00	54.50	44.50	5.25	2.25	
A-1660	8.00	9.75	5.62	6.12	5.38	7.00	8.25	.62 x 1.12	.19	3.00	3.00	.50	6.00	(6) .25	55.00	66.50	56.50	5.25	2.25	
A-1672	8.00	9.75	5.62	6.12	5.38	7.00	8.25	.62 x 1.12	.19	3.00	3.00	.50	6.00	(6) .25	67.00	78.50	68.50	5.25	2.25	

*SAF-1200 5.88. **SAF-1600 7.38.

NOTE: We reserve the right to make reasonable design changes without notice. Consult factory. All dimensions are inches.

Dimensions

Four Pass

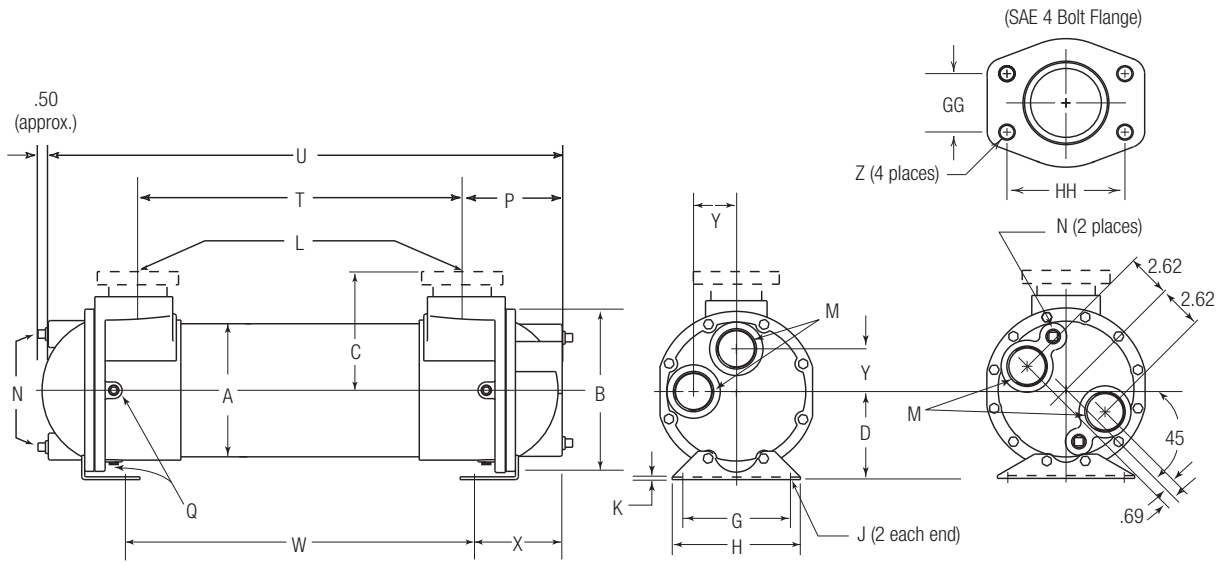

**A-600, A-800, A-1000
A-1200 Series**

A-1600 Series

Flange Size	GG	HH	Z - CF	Z - CFM
1	1.03	2.06	3/8-16 UNC	M-10
1.50	1.41	2.75	1/2-13 UNC	M-12
2	1.69	3.06	1/2-13 UNC	M-12
3	2.44	4.19	5/8-11 UNC	M-16

Model	A Dia.	B Dia.	C		D	G	H	J	K	L		M NPT	N NPT	P	Q NPT	T	U	W	X	Y
			NPT/BSPP SAE O-Ring	SAE 4 Bolt Flange						NPT/BSPP Flange	SAE O-Ring									
A-608	3.12	4.19	2.44	C/F	2.44	2.50	3.50	.38 x .88	.12	1.00	#16,	.75	.38	2.31	(2) .25	6.12	10.88	5.47	2.81	1.00
A-614	3.12	4.19	2.44	C/F	2.44	2.50	3.50	.38 x .88	.12	1.00	1 1/8-12	.75	.38	2.31	(2) .25	12.12	16.88	11.47	2.81	1.00
A-624	3.12	4.19	2.44	C/F	2.44	2.50	3.50	.38 x .88	.12	1.00	UNF-2b	.75	.38	2.31	(2) .25	22.12	26.88	21.47	2.81	1.00
A-814	4.12	5.88	3.12	C/F	3.50	3.50	4.75	.50 x 1.62	.12	1.50	#24, 1 1/8-12 UN-2B	.75	.38	3.44	(6) .38	11.12	17.62	12.88	2.56	1.06
A-824	4.12	5.88	3.12	C/F	3.50	3.50	4.75	.50 x 1.62	.12	1.50		.75	.38	3.44	(6) .38	21.12	27.62	22.88	2.56	1.06
A-836	4.12	5.88	3.12	C/F	3.50	3.50	4.75	.50 x 1.62	.12	1.50		.75	.38	3.44	(6) .38	33.12	39.62	34.88	2.56	1.06
A-1014	5.12	6.50	3.62	4.34	3.50	4.00	5.00	.44 x 2.20	.12	1.50		1.00	.38	3.56	(6) .25	11.12	18.38	11.75	3.25	1.69
A-1024	5.12	6.50	3.62	4.34	3.50	4.00	5.00	.44 x 2.20	.12	1.50	1.00	.38	3.56	(6) .25	21.12	28.38	21.75	3.25	1.69	
A-1036	5.12	6.50	3.62	4.34	3.50	4.00	5.00	.44 x 2.20	.12	1.50	1.00	.38	3.56	(6) .25	33.12	40.38	33.75	3.25	1.69	
A-1224	6.12	7.50	4.25	4.84"	4.12	5.00	6.00	.50 x .88	.12	2.00	#32, 2 1/2-12 UN-2B	1.50	.50	4.25	(6) .25	20.50	29.00	21.50	3.75	2.00
A-1236	6.12	7.50	4.25	4.84"	4.12	5.00	6.00	.50 x .88	.12	2.00		1.50	.50	4.25	(6) .25	32.50	41.00	33.50	3.75	2.00
A-1248	6.12	7.50	4.25	4.84"	4.12	5.00	6.00	.50 x .88	.12	2.00		1.50	.50	4.25	(6) .25	44.50	53.00	45.50	3.75	2.00
A-1260	6.12	7.50	4.25	4.84"	4.12	5.00	6.00	.50 x .88	.12	2.00		1.50	.50	4.25	(6) .25	56.50	65.00	57.50	3.75	2.00
A-1624	8.00	9.75	5.62	6.12"	5.38	7.00	8.25	.62 x 1.12	.19	3.00	—	2.00	.50	6.00	(6) .25	19.00	30.75	20.50	5.25	—
A-1636	8.00	9.75	5.62	6.12"	5.38	7.00	8.25	.62 x 1.12	.19	3.00	—	2.00	.50	6.00	(6) .25	31.00	42.75	44.50	5.25	—
A-1648	8.00	9.75	5.62	6.12"	5.38	7.00	8.25	.62 x 1.12	.19	3.00	—	2.00	.50	6.00	(6) .25	43.00	54.75	44.50	5.25	—
A-1660	8.00	9.75	5.62	6.12"	5.38	7.00	8.25	.62 x 1.12	.19	3.00	—	2.00	.50	6.00	(6) .25	55.00	66.75	56.50	5.25	—
A-1672	8.00	9.75	5.62	6.12"	5.38	7.00	8.25	.62 x 1.12	.19	3.00	—	2.50	.50	6.00	(6) .25	67.00	78.75	68.50	5.25	—

*SAF-1200 5.88. **SAF-1600 7.38.

NOTE: We reserve the right to make reasonable design changes without notice. Consult factory. All dimensions are inches.