

SAF Series – Bare Tube Bundle Shell & Tube Water to Oil Cooling

The A/SA Series is very versatile in its ability to accommodate multiple application requirements. 600 and 800 sizes offer 1/4" tube and 1000, 1200, and 1600 sizes feature 3/8" tube.

A series is a non-ferrous, Brass construction, which makes it ideal for water to water, including sea water cooling applications.

The SA series is a competitively priced steel construction version of the A series, and mainly used for standard hydraulic applications. Steel/cast iron components offer a lower cost solution. SA is only available in 1200 and 1600 sizes.



Options

Non-ferrous construction (water-to-water service)

90/10 copper nickel cooling tubes, bronze end bonnets for sea water service and zinc anodes

How to Order

Model Series

SAF - SAE Flange (with UNC threads) Shell Side connections x NPT Tube Side connections

Model Size Selected

608, 614, 624, 814, 824, 836, 1014, 1024, 1036, 1224, 1236, 1248, 1260, 1624, 1636, 1648, 1660, 1672
(See Performance Curve Chart on page 3 for sizes)

Baffle Spacing

1, 1.5, 2, 3, 4, 6
(See Performance Curve Chart on page 3 for options)

Tube Diameter Code

4 - 1/4" (600 & 800 Sizes only)
6 - 3/8" (1000, 1200 & 1600 Sizes only)

Tubeside

O - One Pass
T - Two Pass
F - Four Pass

Shell Material

Blank - Steel (SA Series Only)
BR - Brass

Cooling Tube Material

Blank - Copper
CN - Copper Nickel

End Bonnet Material

Blank - Cast Iron
B - Bronze (A Series Only)

Zinc Anodes

Blank - None
Z - Zinc

Features

ITT Interchange

B or HC Series is Recommended for New Applications

Sea Water Applications (A Series Only), End Model Code with BR-CN-B-Z

Water to Water Applications (A Series Only)

Cooling Tube Side Material Options

- Standard Steel
- Copper Nickel
- Bronze

Multiple Connection Options (shell x tube)

- NPT x NPT
- SAE x NPT
- Sae Code 61 x NPT
- BSPP x BSP

End Bonnets Removable for Servicing

Mounting Feet Included (May be Rotated in 90° Increments)

Ratings

Maximum Operating Pressure

- Shell Side 300 PSI

Maximum Operating Pressure

- Tube Side 150 PSI

Maximum Operating Temperature

300°F

Heat Rejection from 2-350 HP

Oil Flow from 3-200 GPM

Materials

Shell Steel/Brass

Tubes Copper/Copper Nickel

Hubs & Tubesheets

Steel/Brass

Baffles Brass

End Bonnets Cast Iron/Bronze

Mounting Brackets Steel

Gaskets Nitrile Rubber/Cellulose Fiber

Nameplate Aluminum Foil

Piping Diagram

One Pass

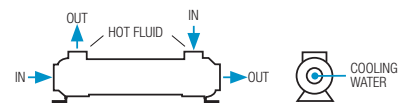

Two and Four Pass



Specific applications may have different piping arrangements. Contact factory for assistance.

Performance Curves

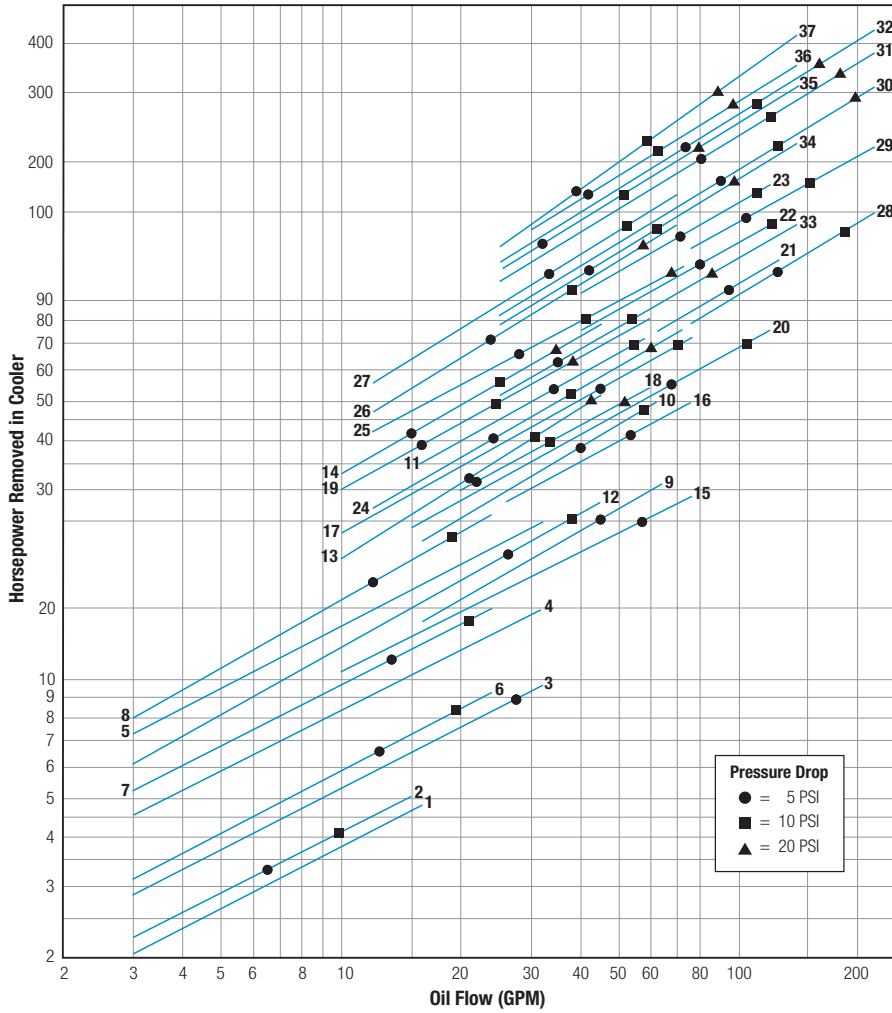

Curve Number	Model	Shipping Weight (LBS)
3	A-608-2-4-F	12
4	A-614-4-4-F	17
5	A-624-4-4-F	20
6	A-608-1-4-F	12
7	A-614-1.5-4-F	17
8	A-624-2-4-F	20
9	A-814-3-4-F	40
10	A-824-4-4-F	50
11	A-836-4-4-F	58
12	A-814-1.5-4-F	40
13	A-824-2-4-F	50
14	A-836-2-4-F	58
15	A-1014-3-6-F	49
16	A-1024-4-6-F	63
17	A-1036-4-6-F	72
18	A-1024-2-6-F	63
19	A-1036-2-6-F	72
20	A-1224-4-6-F	78
21	A-1236-6-6-F	118
22	A-1248-6-6-F	143
23	A-1260-6-6-F	165
24	A-1224-2-6-F	78
25	A-1236-3-6-F	118
26	A-1248-3-6-F	143
27	A-1260-4-6-F	165
28	A-1624-6-6-F	180
29	A-1636-6-6-F	210
30	A-1648-6-6-F	250
31	A-1660-6-6-F	286
32	A-1672-6-6-F	330
33	A-1624-2-6-F	180
34	A-1636-3-6-F	210
35	A-1648-3-6-F	250
36	A-1660-4-6-F	286
37	A-1672-4-6-F	330

Shipping weights are approximate.

Dimensions

One Pass

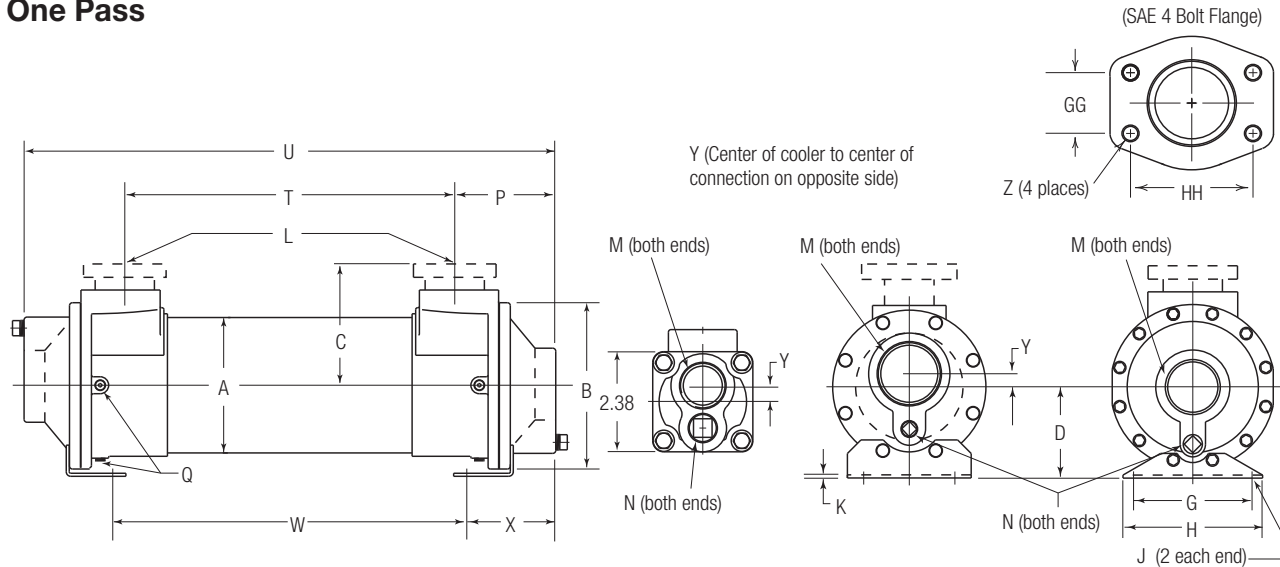

**A-600
A-800 Series**

**A-1000, A-1200
A-1600 Series**

Flange Size	GG	HH	Z - CF	Z - CFM
1	1.03	2.06	3/8-16 UNC	M-10
1.50	1.41	2.75	1/2-13 UNC	M-12
2	1.69	3.06	1/2-13 UNC	M-12
3	2.44	4.19	5/8-11 UNC	M-16

Model	A Dia.	B Dia.	C		D	G	H	J	K	L		M NPT	N NPT	P	Q NPT	T	U	W	X	Y	
			NPT/BSPP SAE O-Ring	SAE 4 Bolt Flange						NPT/BSPP Flange	SAE O-Ring										
A-608	3.12	4.19	2.44	C/F	2.44	2.50	3.50	.38 x .88	.12	1.00	#16,	1.50	.38	2.56	(2) .25	6.12	11.25	5.47	3.06	.38	
A-614	3.12	4.19	2.44	C/F	2.44	2.50	3.50	.38 x .88	.12	1.00	1 1/4-12	1.50	.38	2.56	(2) .25	12.12	17.25	11.47	3.06	.38	
A-624	3.12	4.19	2.44	C/F	2.44	2.50	3.50	.38 x .88	.12	1.00	UNF-2B	1.50	.38	2.56	(2) .25	22.12	27.25	21.47	3.06	.38	
A-814	4.12	5.88	3.12	C/F	3.50	3.50	4.75	.50 x 1.62	.12	1.50	#24, 1 1/8-12 UN-2B	2.00	.38	3.44	(6) .38	11.12	18.00	12.88	2.56	.50	
A-824	4.12	5.88	3.12	C/F	3.50	3.50	4.75	.50 x 1.62	.12	1.50		2.00	.38	3.44	(6) .38	21.12	28.00	22.88	2.56	.50	
A-836	4.12	5.88	3.12	C/F	3.50	3.50	4.75	.50 x 1.62	.12	1.50		2.00	.38	3.44	(6) .38	33.12	40.00	34.88	2.56	.50	
A-1014	5.12	6.50	3.62	4.34	3.50	4.00	5.00	.44 x 2.20	.12	1.50		2.50	.38	3.69	(6) .25	11.12	18.50	11.75	3.38	.50	
A-1024	5.12	6.50	3.62	4.34	3.50	4.00	5.00	.44 x 2.20	.12	1.50		2.50	.38	3.69	(6) .25	21.12	28.50	21.75	3.38	.50	
A-1036	5.12	6.50	3.62	4.34	3.50	4.00	5.00	.44 x 2.20	.12	1.50		2.50	.38	3.69	(6) .25	33.12	40.50	33.75	3.38	.50	
A-1224	6.12	7.50	4.25	4.84"	4.12	5.00	6.00	.50 x .88	.12	2.00		#32, 2 1/2-12 UN-2B	3.00	.50	4.25	(6) .25	20.50	29.00	21.50	3.75	.50
A-1236	6.12	7.50	4.25	4.84"	4.12	5.00	6.00	.50 x .88	.12	2.00			3.00	.50	4.25	(6) .25	32.50	41.00	33.50	3.75	.50
A-1248	6.12	7.50	4.25	4.84"	4.12	5.00	6.00	.50 x .88	.12	2.00			3.00	.50	4.25	(6) .25	44.50	53.00	45.50	3.75	.50
A-1260	6.12	7.50	4.25	4.84"	4.12	5.00	6.00	.50 x .88	.12	2.00			3.00	.50	4.25	(6) .25	56.50	65.00	57.50	3.75	.50
A-1624	8.00	9.75	5.62	6.12"	5.38	7.00	8.25	.62 x 1.12	.19	3.00	—	3.00	.50	6.00	(6) .25	19.00	31.00	20.50	5.25	.50	
A-1636	8.00	9.75	5.62	6.12"	5.38	7.00	8.25	.62 x 1.12	.19	3.00	—	3.00	.50	6.00	(6) .25	31.00	43.00	44.50	5.25	.50	
A-1648	8.00	9.75	5.62	6.12"	5.38	7.00	8.25	.62 x 1.12	.19	3.00	—	3.00	.50	6.00	(6) .25	43.00	55.00	44.50	5.25	.50	
A-1660	8.00	9.75	5.62	6.12"	5.38	7.00	8.25	.62 x 1.12	.19	3.00	—	3.00	.50	6.00	(6) .25	55.00	67.00	56.50	5.25	.50	
A-1672	8.00	9.75	5.62	6.12"	5.38	7.00	8.25	.62 x 1.12	.19	3.00	—	3.00	.50	6.00	(6) .25	67.00	79.00	68.50	5.25	.50	

SAF-1200 5.88. *SAF-1600 7.38.

NOTE: We reserve the right to make reasonable design changes without notice. Consult factory. All dimensions are inches.

Dimensions

Two Pass

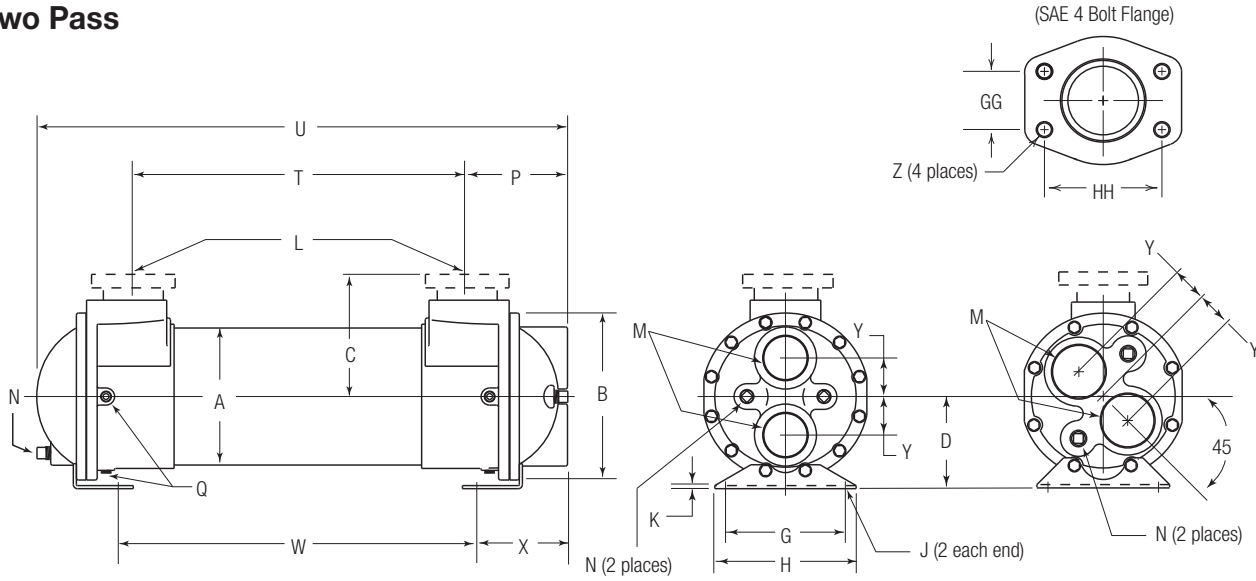

**A-600, A-800, A-1000
A-1600 Series**

A-1200 Series

Flange Size	GG	HH	Z - CF	Z - CFM
1	1.03	2.06	3/8-16 UNC	M-10
1.50	1.41	2.75	1/2-13 UNC	M-12
2	1.69	3.06	1/2-13 UNC	M-12
3	2.44	4.19	5/8-11 UNC	M-16

Model	A Dia.	B Dia.	C		D	G	H	J	K	L		M NPT	N NPT	P	Q NPT	T	U	W	X	Y
			NPT/BSPP SAE O-Ring	SAE 4 Bolt Flange						NPT/BSPP Flange	SAE O-Ring									
A-608	3.12	4.19	2.44	C/F	2.44	2.50	3.50	.38 x .88	.12	1.00	1.00	.38	2.44	(2) .25	6.12	10.75	5.47	2.94	1.00	
A-614	3.12	4.19	2.44	C/F	2.44	2.50	3.50	.38 x .88	.12	1.00	1.00	.38	2.44	(2) .25	12.12	16.75	11.47	2.94	1.00	
A-624	3.12	4.19	2.44	C/F	2.44	2.50	3.50	.38 x .88	.12	1.00	1.00	.38	2.44	(2) .25	22.12	26.75	21.47	2.94	1.00	
A-814	4.12	5.88	3.12	C/F	3.50	3.50	4.75	.50 x 1.62	.12	1.50	1.50	.38	3.44	(6) .38	11.12	17.62	12.88	2.56	1.19	
A-824	4.12	5.88	3.12	C/F	3.50	3.50	4.75	.50 x 1.62	.12	1.50	1.50	.38	3.44	(6) .38	21.12	27.62	22.88	2.56	1.19	
A-836	4.12	5.88	3.12	C/F	3.50	3.50	4.75	.50 x 1.62	.12	1.50	1.50	.38	3.44	(6) .38	33.12	39.62	34.88	2.56	1.19	
A-1014	5.12	6.50	3.62	4.34	3.50	4.00	5.00	.44 x 2.20	.12	1.50	1.50	.38	3.69	(6) .25	11.12	18.31	11.75	3.38	1.50	
A-1024	5.12	6.50	3.62	4.34	3.50	4.00	5.00	.44 x 2.20	.12	1.50	1.50	.38	3.69	(6) .25	21.12	28.31	21.75	3.38	1.50	
A-1036	5.12	6.50	3.62	4.34	3.50	4.00	5.00	.44 x 2.20	.12	1.50	1.50	.38	3.69	(6) .25	33.12	40.31	33.75	3.38	1.50	
A-1224	6.12	7.50	4.25	4.84	4.12	5.00	6.00	.50 x .88	.12	2.00	2.00	.50	4.25	(6) .25	20.50	28.75	21.50	3.75	1.56	
A-1236	6.12	7.50	4.25	4.84	4.12	5.00	6.00	.50 x .88	.12	2.00	2.00	.50	4.25	(6) .25	32.50	40.75	33.50	3.75	1.56	
A-1248	6.12	7.50	4.25	4.84	4.12	5.00	6.00	.50 x .88	.12	2.00	2.00	.50	4.25	(6) .25	44.50	52.75	45.50	3.75	1.56	
A-1260	6.12	7.50	4.25	4.84	4.12	5.00	6.00	.50 x .88	.12	2.00	2.00	.50	4.25	(6) .25	56.50	64.75	57.50	3.75	1.56	
A-1624	8.00	9.75	5.62	6.12	5.38	7.00	8.25	.62 x 1.12	.19	3.00	3.00	.50	6.00	(6) .25	19.00	30.50	20.50	5.25	2.25	
A-1636	8.00	9.75	5.62	6.12	5.38	7.00	8.25	.62 x 1.12	.19	3.00	3.00	.50	6.00	(6) .25	31.00	42.50	44.50	5.25	2.25	
A-1648	8.00	9.75	5.62	6.12	5.38	7.00	8.25	.62 x 1.12	.19	3.00	3.00	.50	6.00	(6) .25	43.00	54.50	44.50	5.25	2.25	
A-1660	8.00	9.75	5.62	6.12	5.38	7.00	8.25	.62 x 1.12	.19	3.00	3.00	.50	6.00	(6) .25	55.00	66.50	56.50	5.25	2.25	
A-1672	8.00	9.75	5.62	6.12	5.38	7.00	8.25	.62 x 1.12	.19	3.00	3.00	.50	6.00	(6) .25	67.00	78.50	68.50	5.25	2.25	

*SAF-1200 5.88. **SAF-1600 7.38.

NOTE: We reserve the right to make reasonable design changes without notice. Consult factory. All dimensions are inches.

Dimensions

Four Pass

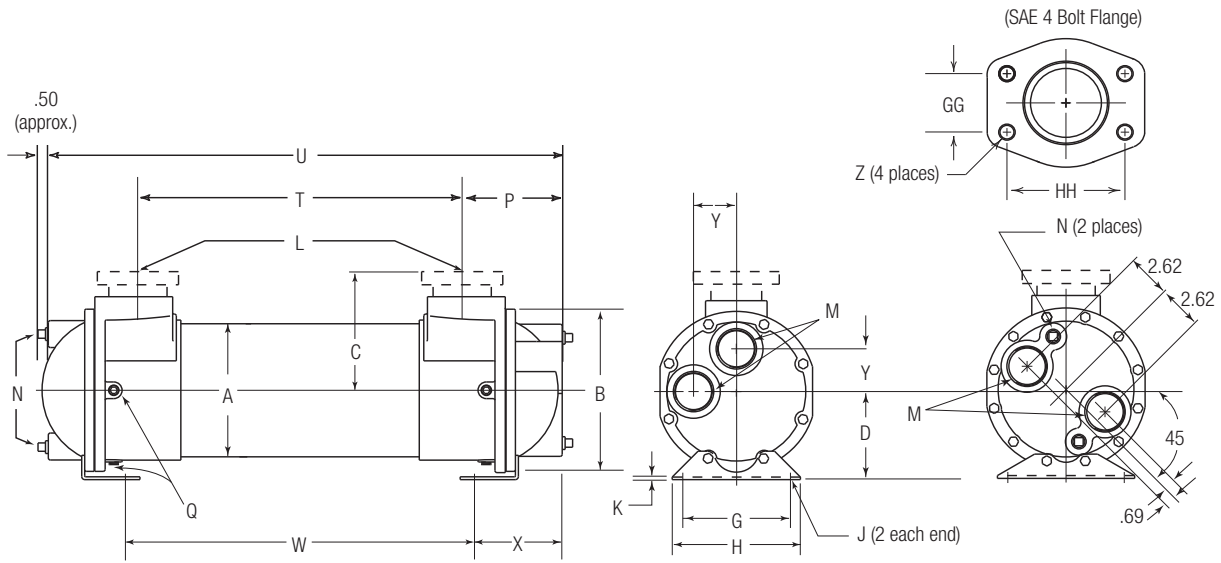

**A-600, A-800, A-1000
A-1200 Series**

A-1600 Series

Flange Size	GG	HH	Z - CF	Z - CFM
1	1.03	2.06	3/8-16 UNC	M-10
1.50	1.41	2.75	1/2-13 UNC	M-12
2	1.69	3.06	1/2-13 UNC	M-12
3	2.44	4.19	5/8-11 UNC	M-16

Model	A Dia.	B Dia.	C		D	G	H	J	K	L		M NPT	N NPT	P	Q NPT	T	U	W	X	Y
			NPT/BSPP SAE O-Ring	SAE 4 Bolt Flange						NPT/BSPP Flange	SAE O-Ring									
A-608	3.12	4.19	2.44	C/F	2.44	2.50	3.50	.38 x .88	.12	1.00	#16,	.75	.38	2.31	(2) .25	6.12	10.88	5.47	2.81	1.00
A-614	3.12	4.19	2.44	C/F	2.44	2.50	3.50	.38 x .88	.12	1.00	1 1/8-12	.75	.38	2.31	(2) .25	12.12	16.88	11.47	2.81	1.00
A-624	3.12	4.19	2.44	C/F	2.44	2.50	3.50	.38 x .88	.12	1.00	UNF-2b	.75	.38	2.31	(2) .25	22.12	26.88	21.47	2.81	1.00
A-814	4.12	5.88	3.12	C/F	3.50	3.50	4.75	.50 x 1.62	.12	1.50	#24, 1 1/8-12 UN-2B	.75	.38	3.44	(6) .38	11.12	17.62	12.88	2.56	1.06
A-824	4.12	5.88	3.12	C/F	3.50	3.50	4.75	.50 x 1.62	.12	1.50		.75	.38	3.44	(6) .38	21.12	27.62	22.88	2.56	1.06
A-836	4.12	5.88	3.12	C/F	3.50	3.50	4.75	.50 x 1.62	.12	1.50		.75	.38	3.44	(6) .38	33.12	39.62	34.88	2.56	1.06
A-1014	5.12	6.50	3.62	4.34	3.50	4.00	5.00	.44 x 2.20	.12	1.50		1.00	.38	3.56	(6) .25	11.12	18.38	11.75	3.25	1.69
A-1024	5.12	6.50	3.62	4.34	3.50	4.00	5.00	.44 x 2.20	.12	1.50	1.00	.38	3.56	(6) .25	21.12	28.38	21.75	3.25	1.69	
A-1036	5.12	6.50	3.62	4.34	3.50	4.00	5.00	.44 x 2.20	.12	1.50	1.00	.38	3.56	(6) .25	33.12	40.38	33.75	3.25	1.69	
A-1224	6.12	7.50	4.25	4.84"	4.12	5.00	6.00	.50 x .88	.12	2.00	#32, 2 1/2-12 UN-2B	1.50	.50	4.25	(6) .25	20.50	29.00	21.50	3.75	2.00
A-1236	6.12	7.50	4.25	4.84"	4.12	5.00	6.00	.50 x .88	.12	2.00		1.50	.50	4.25	(6) .25	32.50	41.00	33.50	3.75	2.00
A-1248	6.12	7.50	4.25	4.84"	4.12	5.00	6.00	.50 x .88	.12	2.00		1.50	.50	4.25	(6) .25	44.50	53.00	45.50	3.75	2.00
A-1260	6.12	7.50	4.25	4.84"	4.12	5.00	6.00	.50 x .88	.12	2.00		1.50	.50	4.25	(6) .25	56.50	65.00	57.50	3.75	2.00
A-1624	8.00	9.75	5.62	6.12"	5.38	7.00	8.25	.62 x 1.12	.19	3.00	—	2.00	.50	6.00	(6) .25	19.00	30.75	20.50	5.25	—
A-1636	8.00	9.75	5.62	6.12"	5.38	7.00	8.25	.62 x 1.12	.19	3.00	—	2.00	.50	6.00	(6) .25	31.00	42.75	44.50	5.25	—
A-1648	8.00	9.75	5.62	6.12"	5.38	7.00	8.25	.62 x 1.12	.19	3.00	—	2.00	.50	6.00	(6) .25	43.00	54.75	44.50	5.25	—
A-1660	8.00	9.75	5.62	6.12"	5.38	7.00	8.25	.62 x 1.12	.19	3.00	—	2.00	.50	6.00	(6) .25	55.00	66.75	56.50	5.25	—
A-1672	8.00	9.75	5.62	6.12"	5.38	7.00	8.25	.62 x 1.12	.19	3.00	—	2.50	.50	6.00	(6) .25	67.00	78.75	68.50	5.25	—

*SAF-1200 5.88. **SAF-1600 7.38.

NOTE: We reserve the right to make reasonable design changes without notice. Consult factory. All dimensions are inches.